

DC operated slim type card relays

Rated thermal current 5 Amps.

■ Description

The RB104 and 105 relays are designed for printed circuit board use. These relays are extremely thin (5mm) and so, can be densely mounted on PC boards. As a result, PC board size and cost can be greatly reduced. Employing of bifurcated contacts ensure high contact reliability, allowing the RB104,105 relays to be used in low-level circuits. Coil voltages are available in ranges from 4.5V to 24V DC.

■ Features

- Thin, miniature size and light weight
The mounting space on the PC board can be reduced.
- UL, CSA and TÜV approved
- Low power consumption
They can be operated by means of non-polarity magnet.
- SIL terminal arrangement
SIL (Single-side In-Line lead) package allows the relays to be mounted easily on PC board.
- Fluxtight construction
- Immersion cleanable

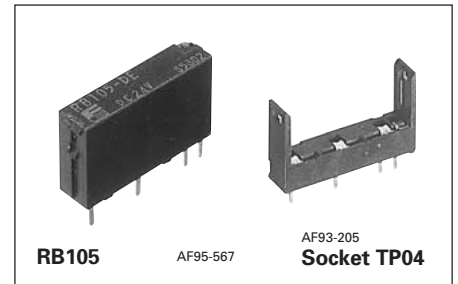

■ **Ordering information**
Specify the following:
1. Type number

■ Types and ratings

Type	Ordering code	Power consumption	Rated voltage	Pick-up voltage	Thermal current	Make and break current (res.load)
RB104	RB104-■	120mW	4.5, 5, 6	70% of rated voltage or less	5A	5A at 250V AC 5A at 30V DC
RB105	RB105-■	200mW	9, 12, 24V DC			

Note: Enter the coil voltage code in the ■ mark as follow
4.5V DC: DC, 5V DC: DY, 6V DC: DA, 9V DC: DD, 12V DC: DB, 24V DC: DE

■ Specifications

Operating time		10ms or less at rated voltage
Release time		5ms or less at rated voltage
Dielectric strength		750V AC rms. 1 min. between open contacts 2,000V AC rms. 1 min. between contact and coil
Stray electrostatic capacity		Approx. 1.4pF between contact and coil
Impulse		4,500V or more 1.2 × 50μs between contact and coil
Insulation resistance		100MΩ at 500V DC megger
Electrical durability	AC	100,000 operations at 220V AC 2A, inductive load
	DC	130,000 operations at 220V AC 3A, resistive load 150,000 operations at 24V DC 1A, inductive load 100,000 operations at 24V DC 5A, resistive load
Mechanical durability		20 million operations
Ambient temperature		-40°C to +70°C(no icing)

■ Type number nomenclature

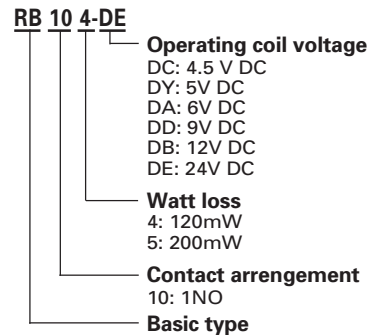

■ Approvals

- UL, CSA and TÜV
UL file No. E44592
CSA file No. LR20479
TUV license No. R9551729

● Ratings

Voltage	Resistive load	Inductive load
120V AC	-	1A
240V AC	5A	-
30V DC	5A	2A (15ms)
120V DC	0.5A	0.2A (15ms)

■ Dimensions, mm

RB104,105

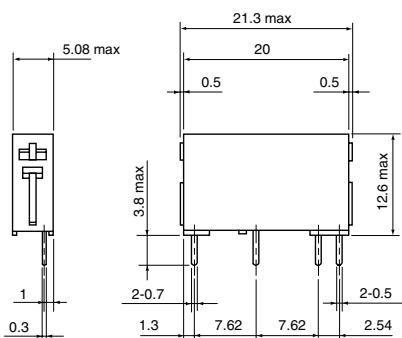

PC board drilling (View from back side)

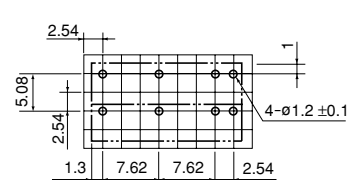

Internal wiring diagram

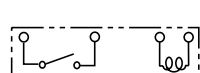

Socket TP04

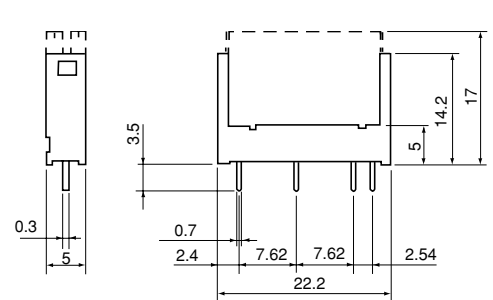

PC board drilling (View from back side)

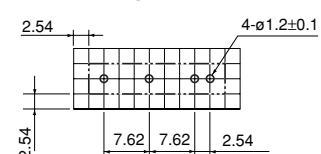

Mass: 3g